

10 mm

Montageanleitung Keilprofil und Windschutz

STYLE - ATTIKA - VISION

# Sicherheit

Bitte die notwendigen und erforderlichen Sicherheitsmaßnahmen einhalten, wie Sicherheitsnetze und Sicherheitsseile während einer Montage an der Außenseite, Sicherheitsbrille, Handschuhe, Helm, usw. Das Glas nicht betreten.



## Absturzgefahr



- Leitern richtig verwenden, wenn Sie das Dach betreten:
  - Leiter in gutem Zustand?
  - Richtig aufgestellt in einem Winkel von 75°?
  - Unten und oben gesichert, sodass sie nicht bewegen kann?
  - Kein schweres Material auf der Leiter mitnehmen (3-Kontaktpunktregel)! Verwenden Sie wenn möglich einen Kran, um das Material hochzuziehen.
- Wenn Sie das Dach betreten müssen, muss eine ausreichend breite Lauffläche vorhanden sein, die auf die Träger der Unterkonstruktion stützt.
- Wenn Sie eine Hebebühne verwenden: immer Auftraggurt tragen und sichern (verpflichtet)! Käfig nicht verlassen.
- Nie rückwärts auf dem Dach laufen, immer vorwärts.
- Sorgen Sie für ausreichend Licht am Arbeitsplatz.

## Herabfallende Gegenstände



- Es ist verboten, um unter oder im Umkreis von weniger als 1 m um herabfallende Gegenstände zu laufen.
- Gefahrenzonen abgrenzen, wo Material während der Konstruktion der Terrassenüberdachung herunterfallen kann.
- Es ist verboten, diese Gefahrenzonen während der Arbeiten zu betreten.

## Quetschgefahr



- Alle Werkzeuge sind im gutem Zustand und sind mit CE-Kennzeichnungen und Sicherheitsbestimmungen gelabelt. Diese dürfen nicht entfernt werden.
- Personen, die diese Werkzeuge benutzen, sind dazu ausgebildet. Die Schütze der Werkzeuge müssen immer vorhanden, in gutem Zustand und richtig eingestellt sein.

## Sturzgefahr, Hindernisse am Boden



- Sicherheit ist wichtig und fängt mit Sauberkeit und Ordnung an. Alles sofort reinigen, nichts herumliegen lassen.
- Müll muss getrennt werden.
- Vorsicht mit elektrischen Kabeln (Stolpergefahr). Nie rückwärts laufen!
- Sorgen Sie für ausreichend Licht am Arbeitsplatz.

## Spitze Gegenstände



- Vorsicht, dass Sie sich nicht in die Finger schneiden oder dass Ihre Finger nicht gequetscht werden, wenn Sie mit Überdachungsteilen arbeiten.
- Achten Sie auf Ihre Hände während der Montage.
- Schnittfeste Handschuhe sind erforderlich.



## Ergonomie

- Lasten immer richtig heben: Gehen Sie in die Knie, bewegen Sie Ihre Füße statt Ihr Rücken, körpernah tragen.
- Lasten von mehr als 25 kg müssen mindestens zu zweit getragen werden.



### Persönliche Schutzausrüstung



- Arbeitskleidung, Sicherheitsschuhe, Helm sind erforderlich.



- Sicherheitsseil (Lifeline) und Auffanggurt sind erforderlich, wenn der Rand nicht ausreichend gesichert ist oder wenn Sicherheitsnetze unter der Überdachung nicht vorhanden sind. Sie sind auch notwendig, wenn Hebebühnen verwendet werden.



- Handschuhe verwenden, wenn Sie mit Dachfensterteilen arbeiten.











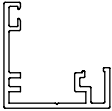

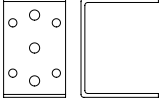
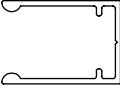
- Sicherheitsbrille und Gehörschutz sind erforderlich, wenn Säge- oder Schleifmaschinen verwendet werden.

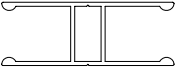
### Immer eine Last Minute Risikoanalyse ausführen!

**Bei Zweifel: HALT! Keine unnötigen Risiken eingehen. Fragen Sie Ihre(n) Vorgesetzte(n) wenn nötig.**

Als solide Basis benötigen Sie Fundamente nach den statischen Erfordernissen. Die wand- und bodenseitige Verankerung ist ebenfalls bauseits zu bemessen. Ermitteln Sie die Position der Fundamente und des Wandprofils anhand der Gesamtabmessungen des Terrassendachs. Da wir als Hersteller die Verarbeitung und Montage nicht überprüfen können, können wir für Montagefehler niemals haftbar gemacht werden.

	WB		KALEER02	
	WC		UP72	2x
	WU		P72	1x
	H		NP	
	C17	 TX25	ZSB	
	C7	 PU	BANDV	PU voegband
	C27			

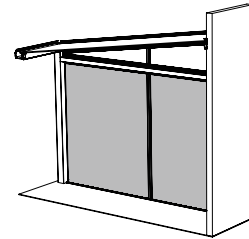
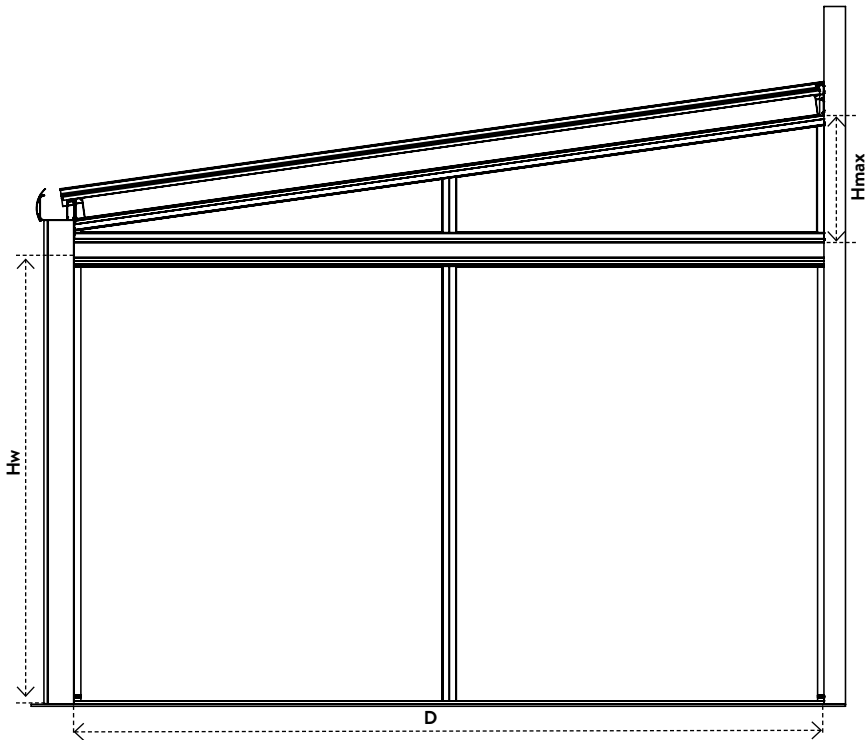
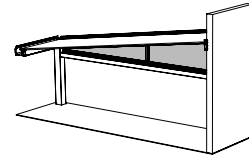
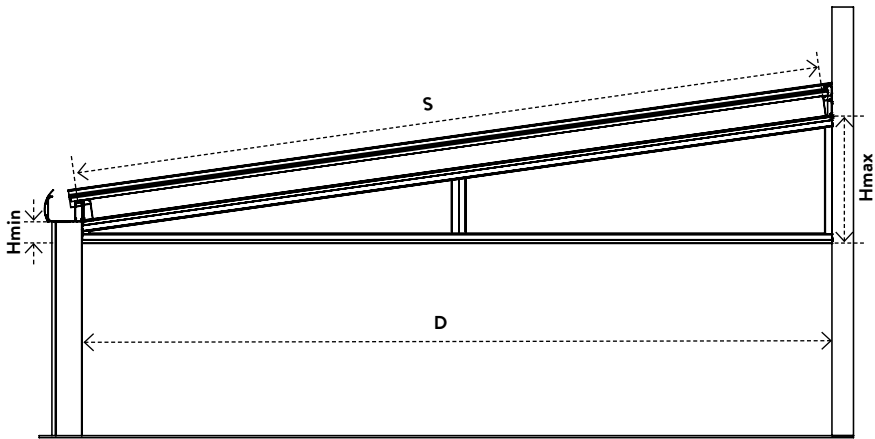

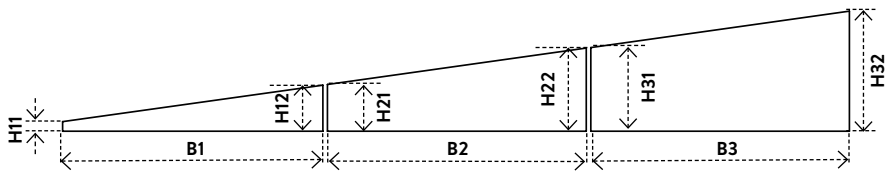
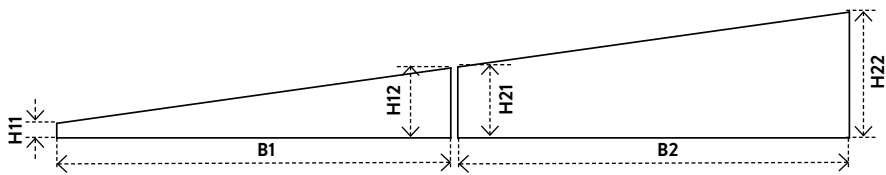
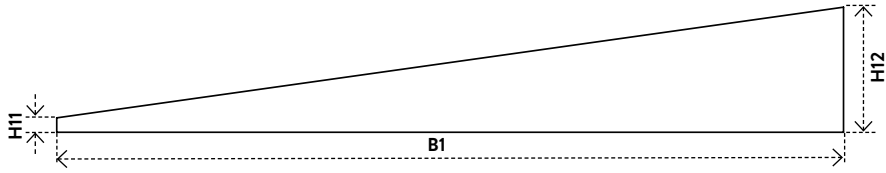

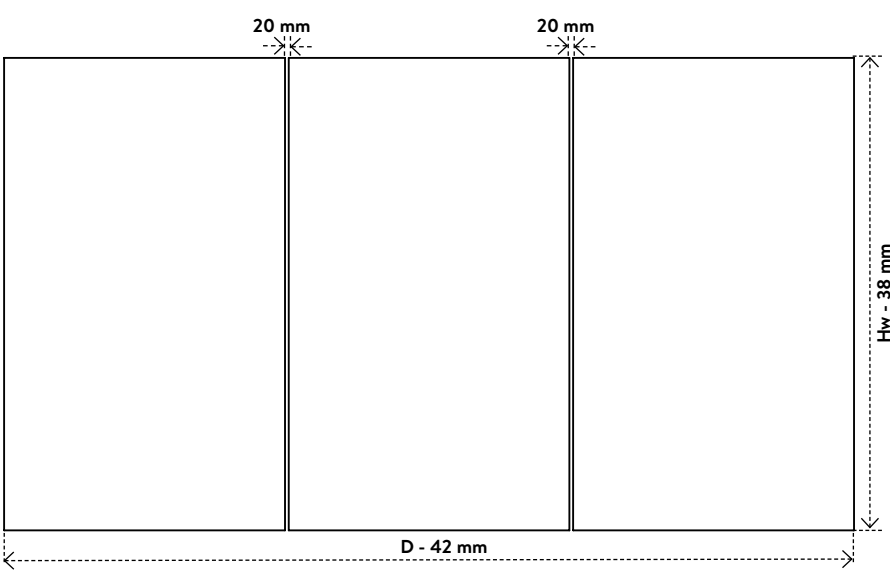
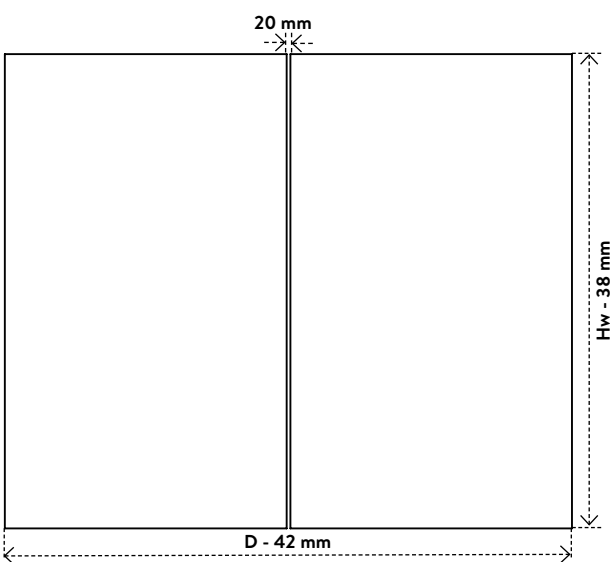
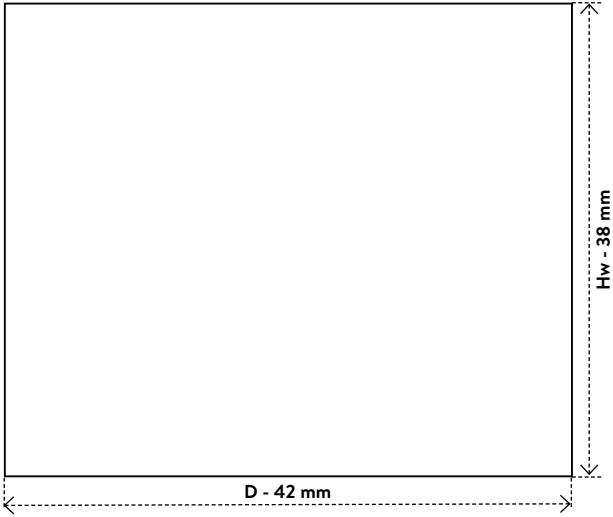

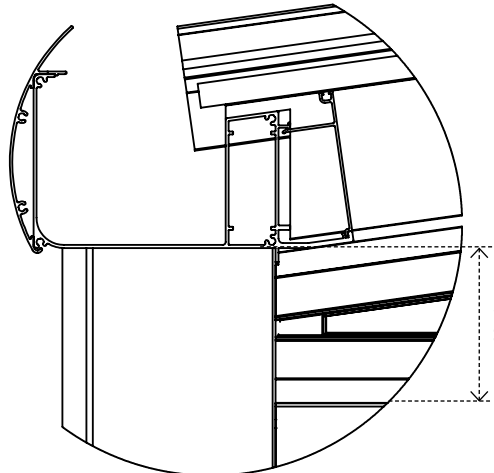
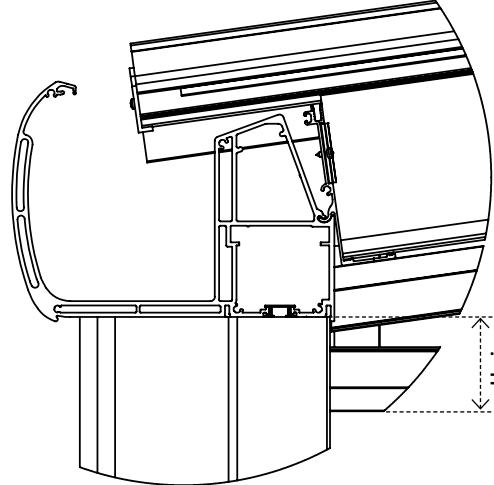
		Hmin (mm)	W1	W2
Rinne STYLE & Attika GX		105	9	0
Rinne VISION		65	9	0



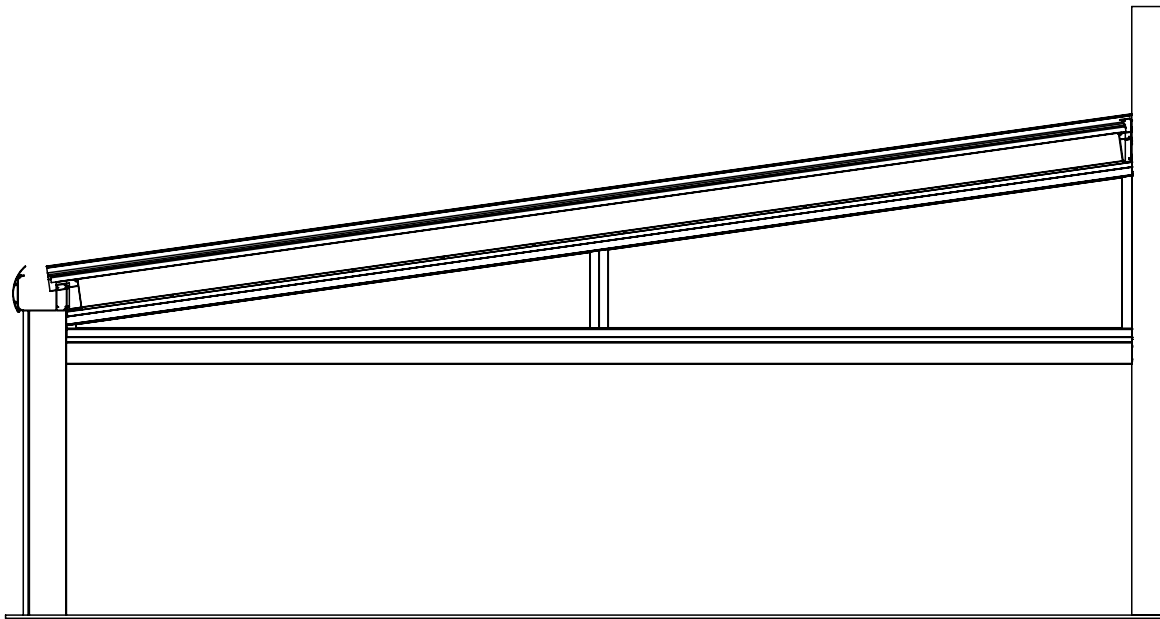

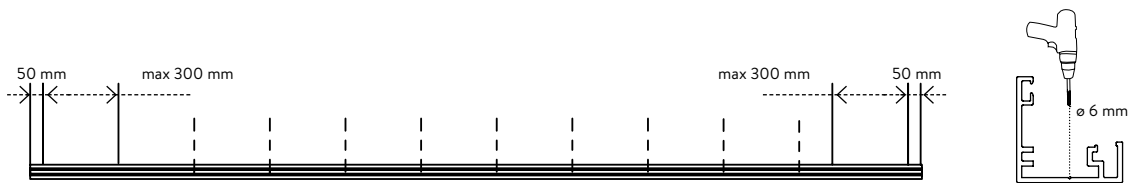
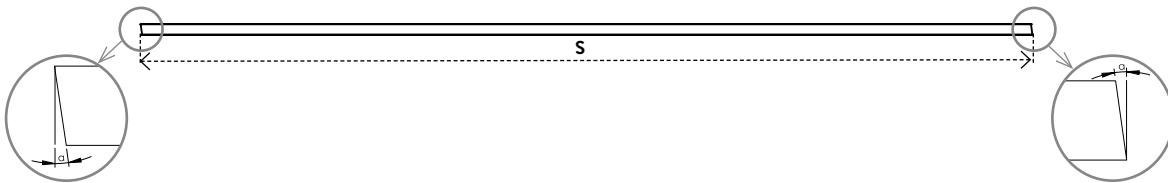
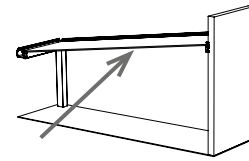
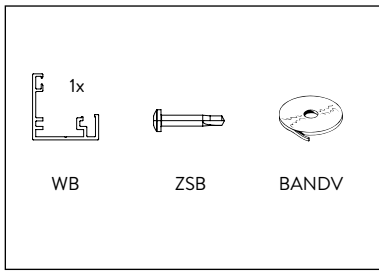

GX

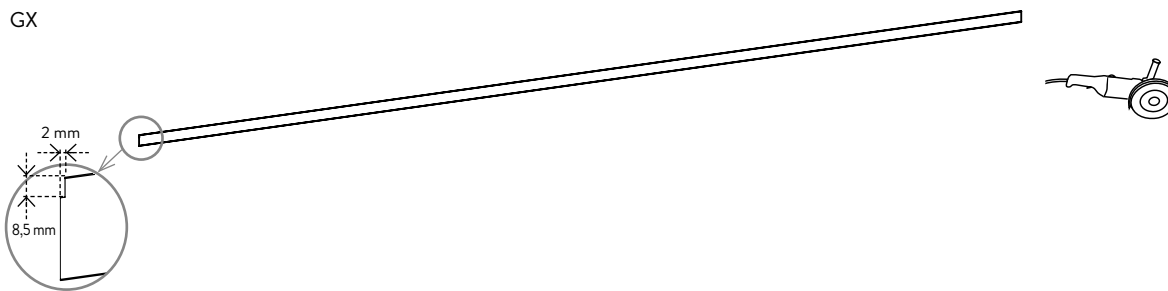

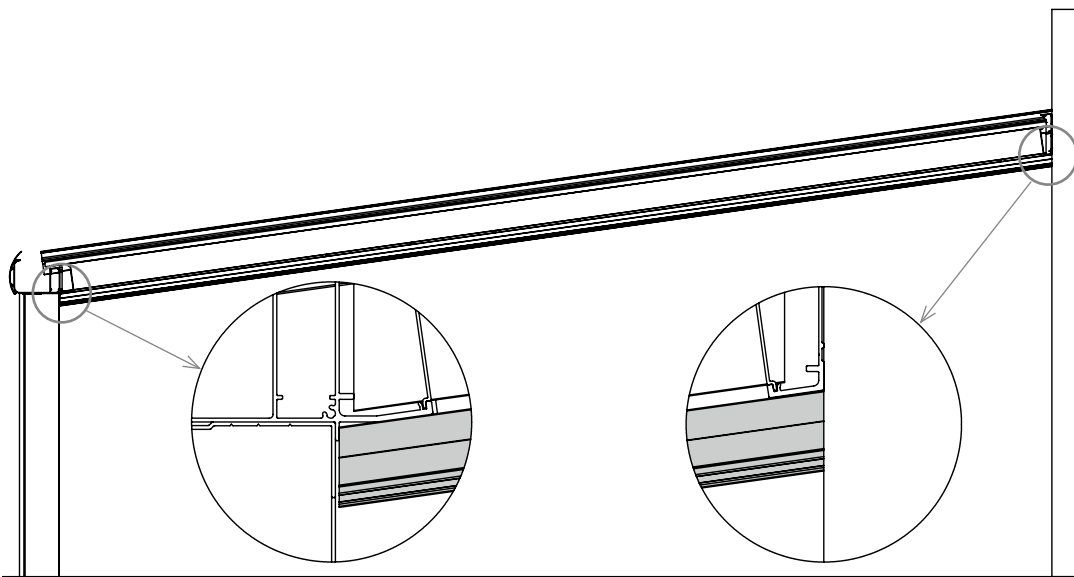
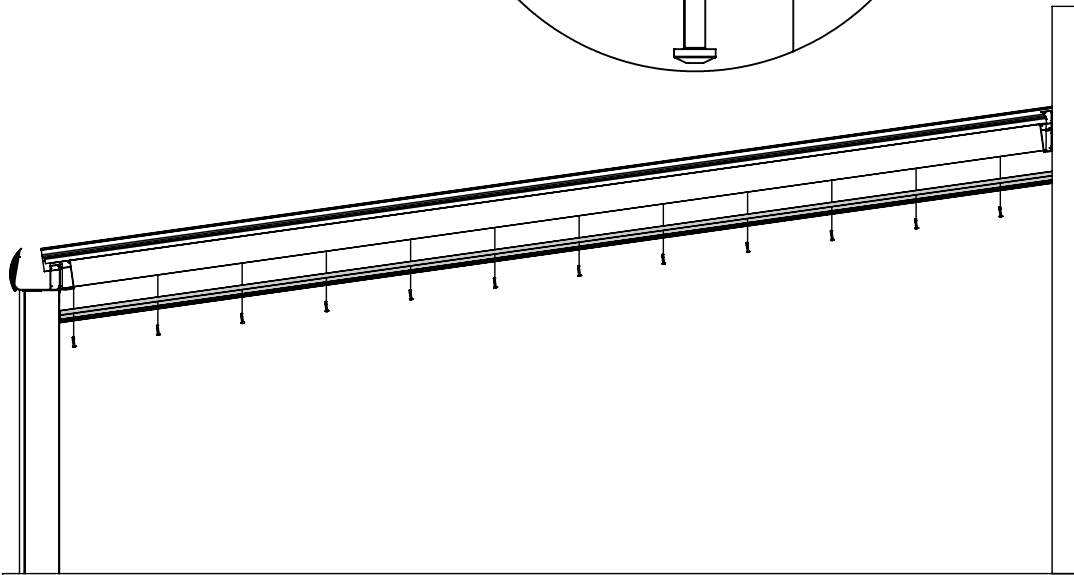
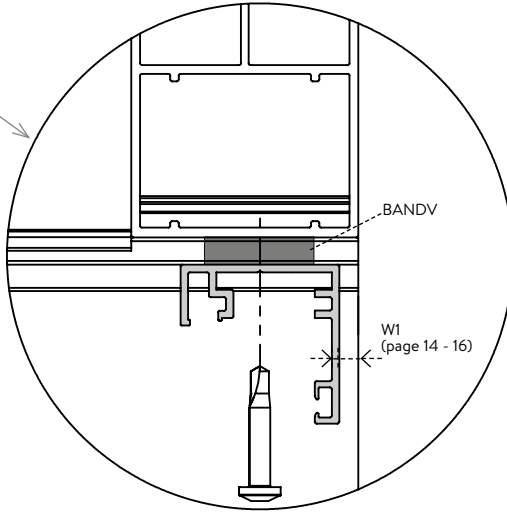
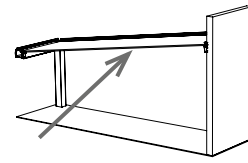
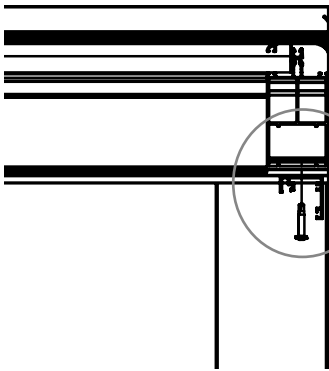

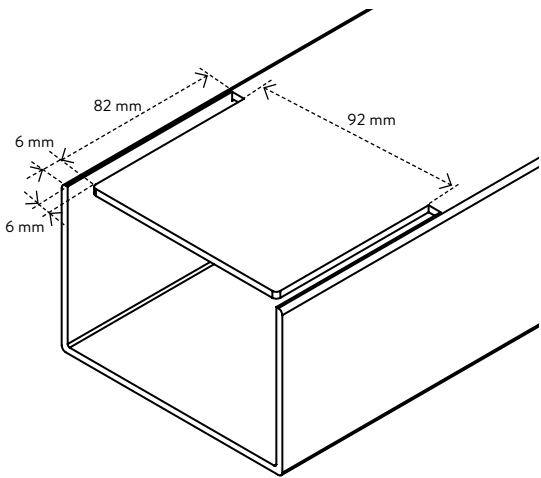
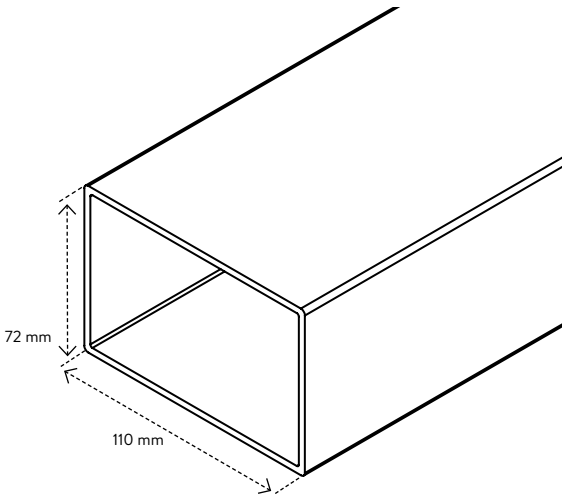
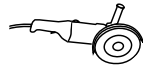
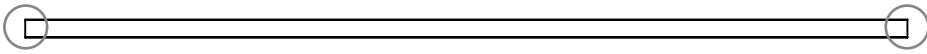
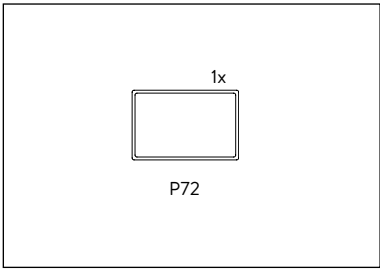

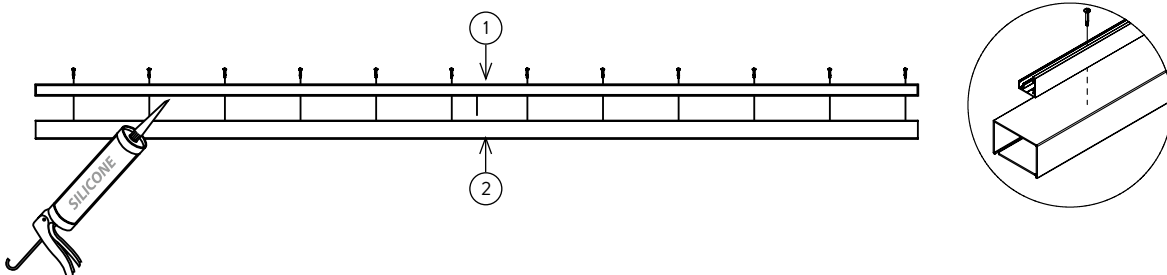
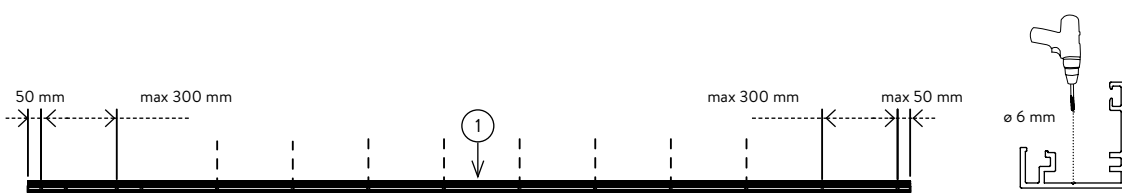
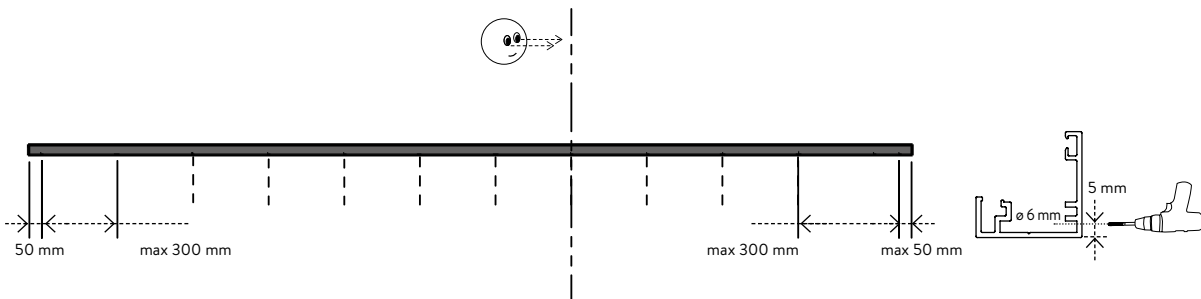
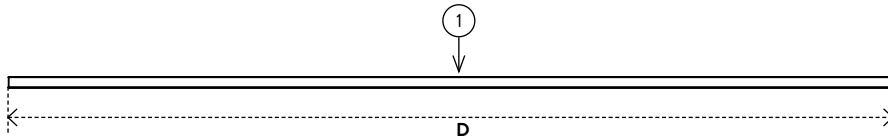
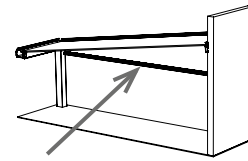
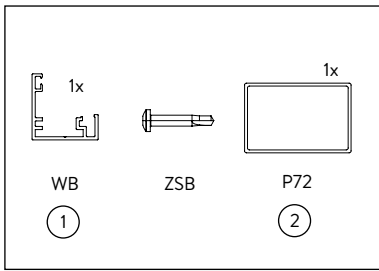

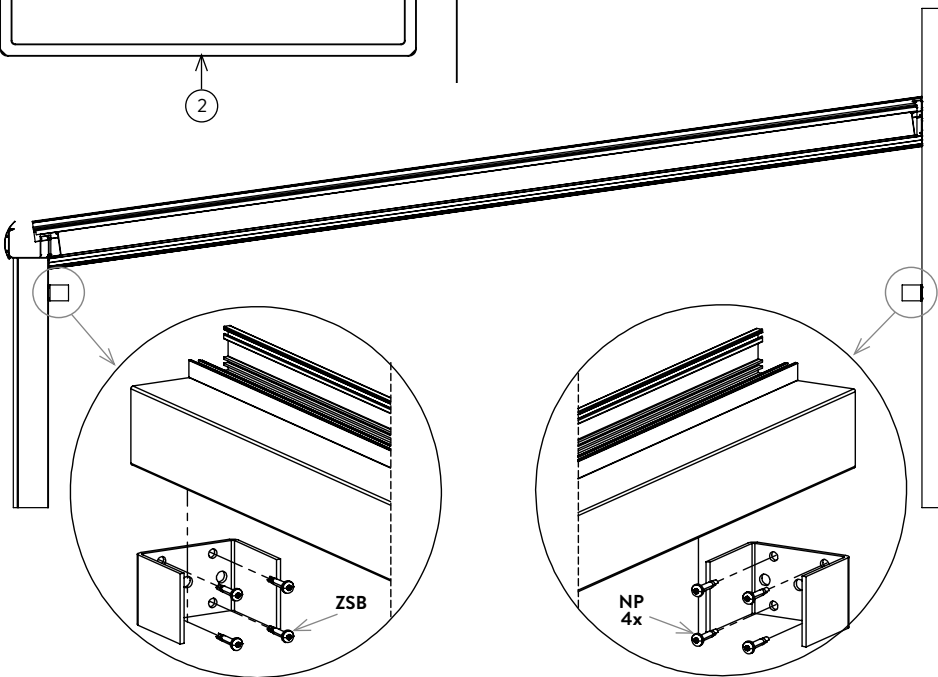
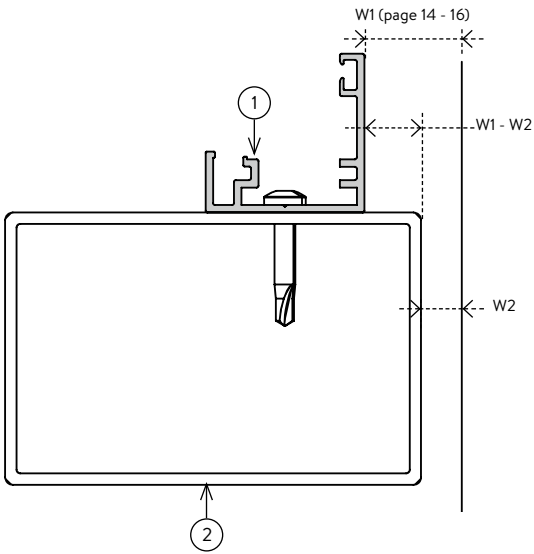
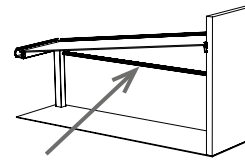
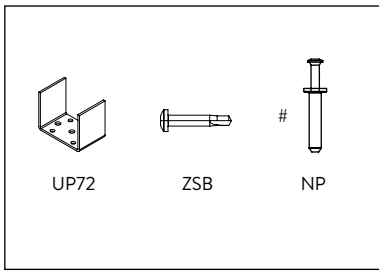

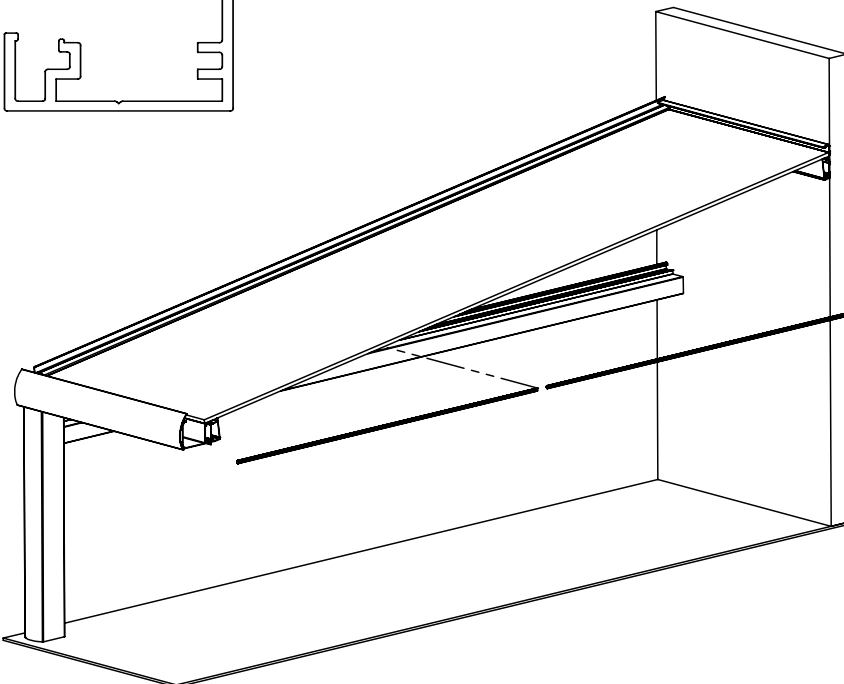
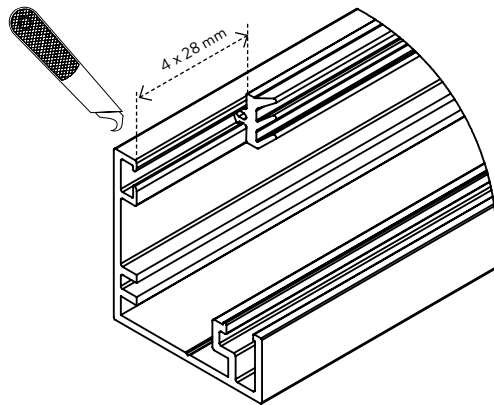
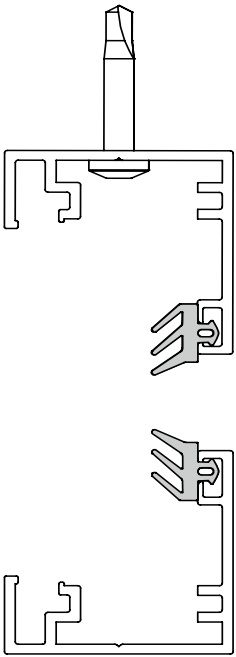
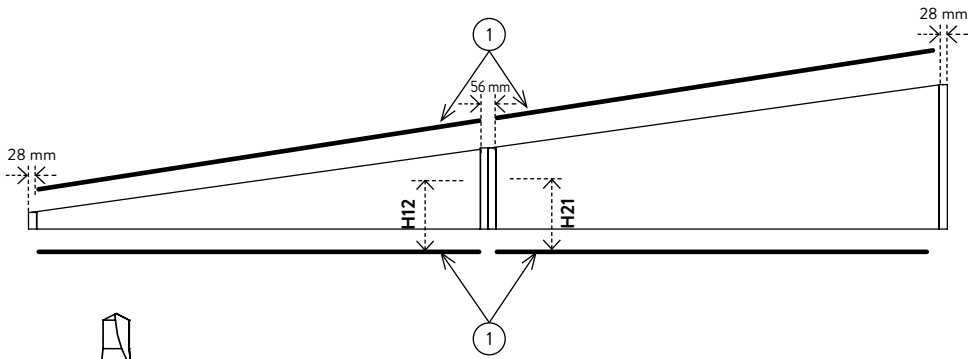
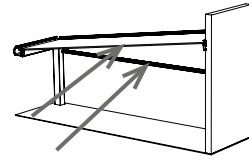
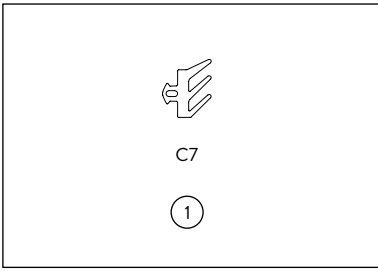

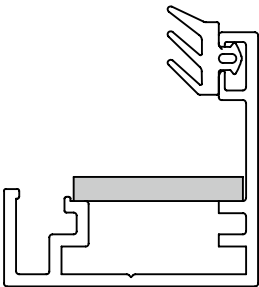
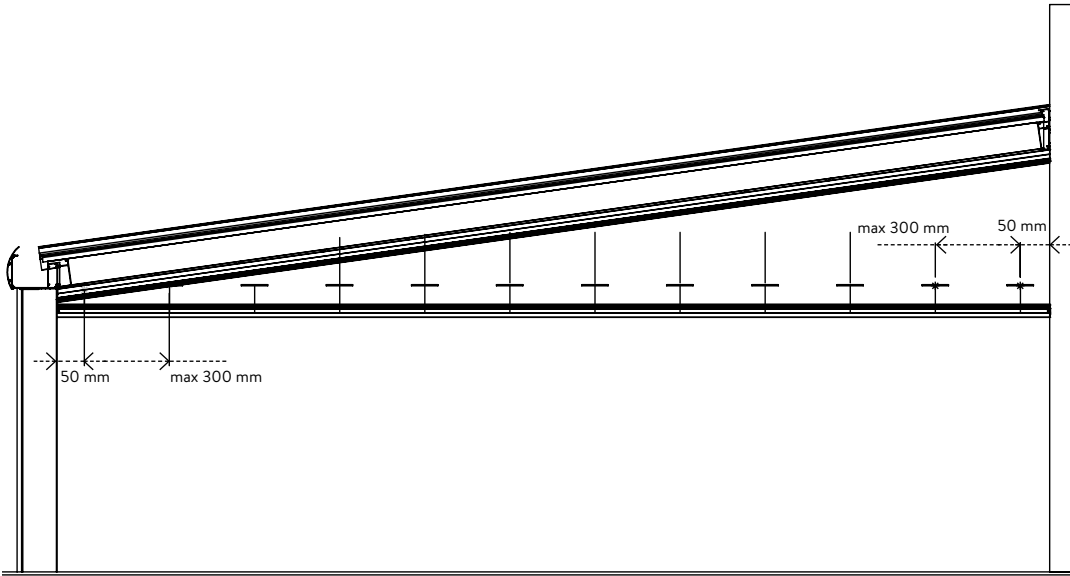
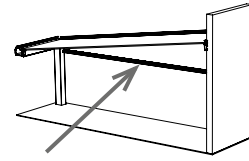
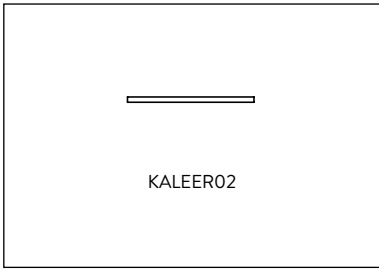



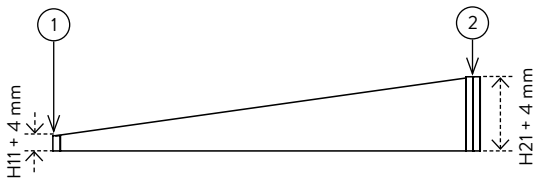
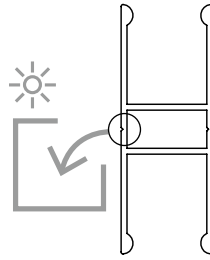
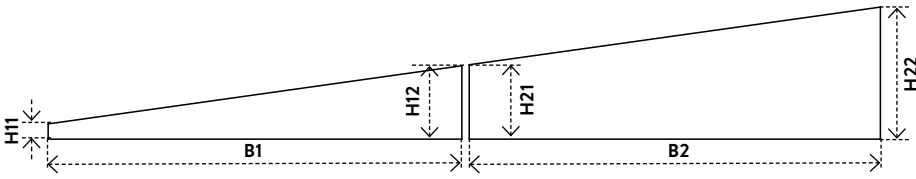
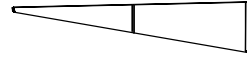
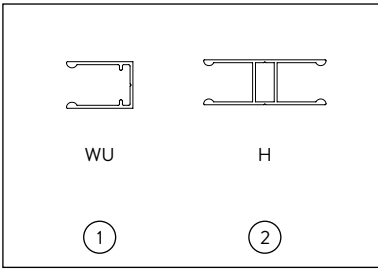

+

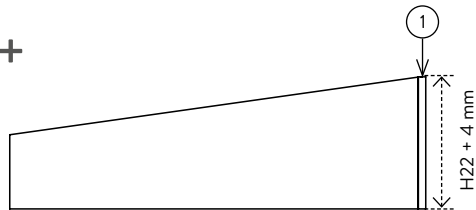

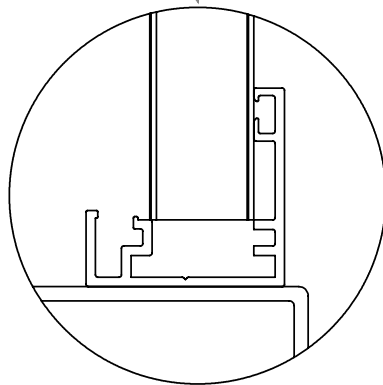
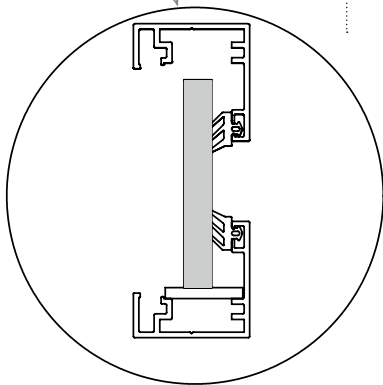
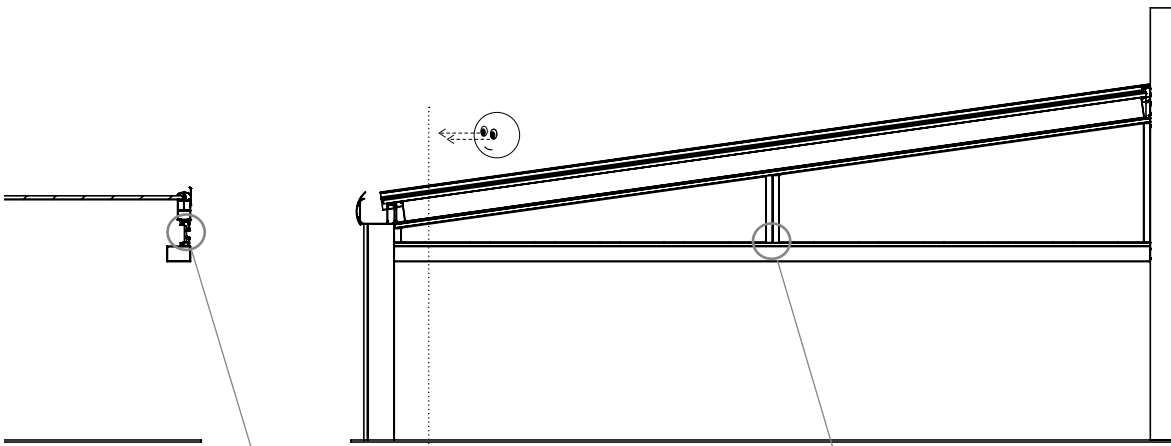
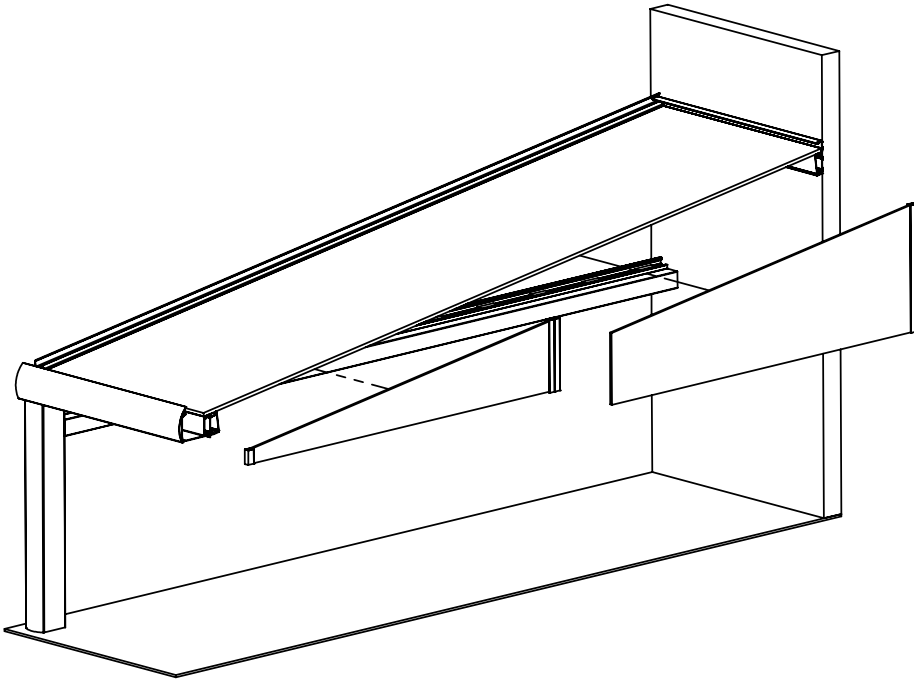
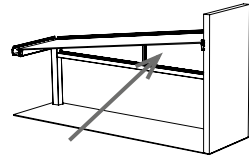

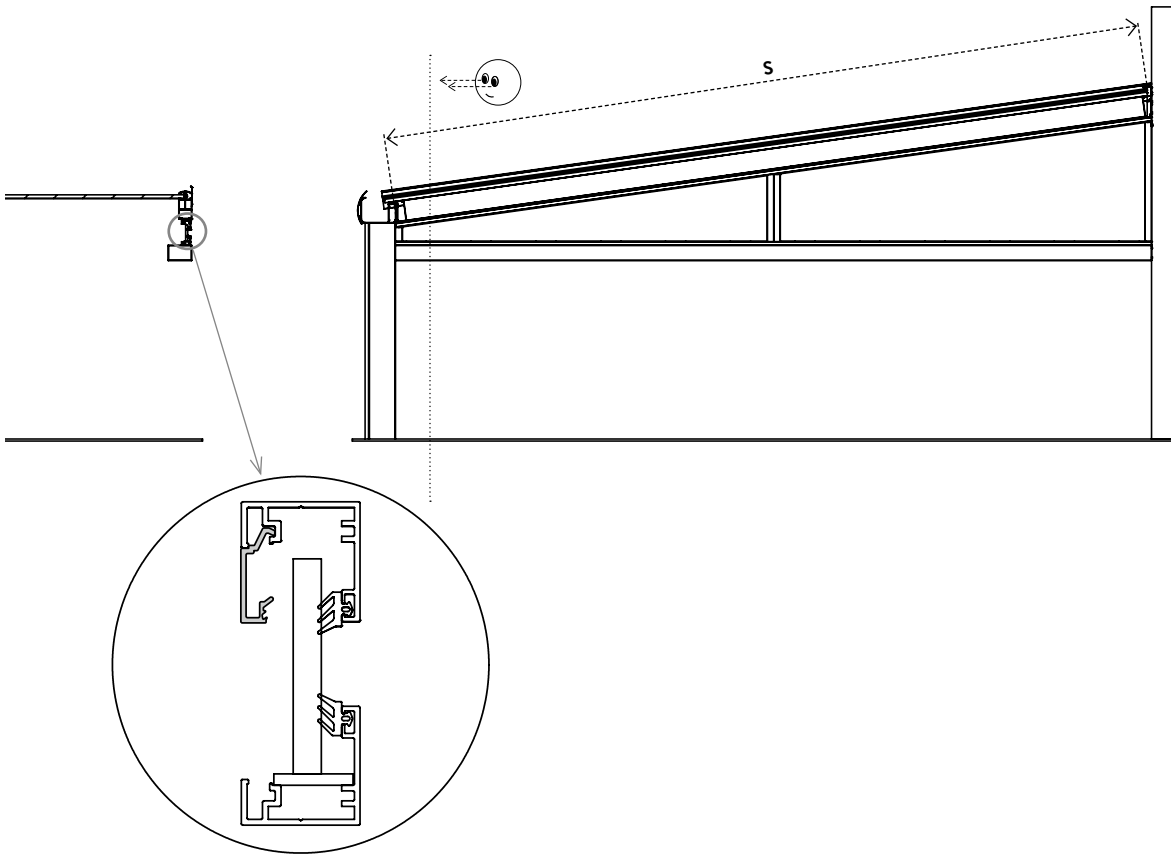
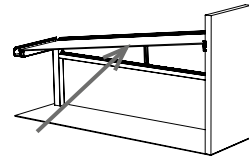
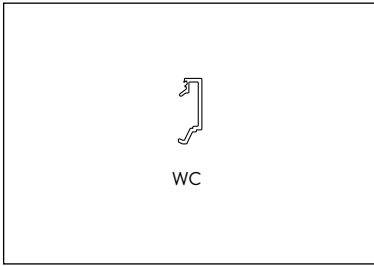

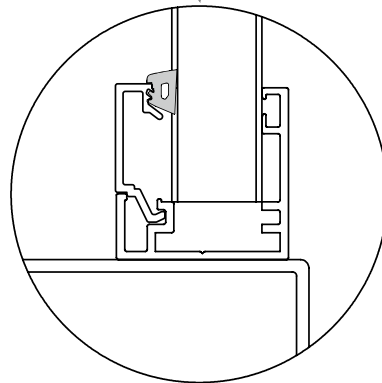
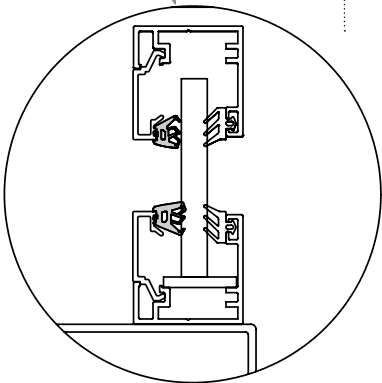
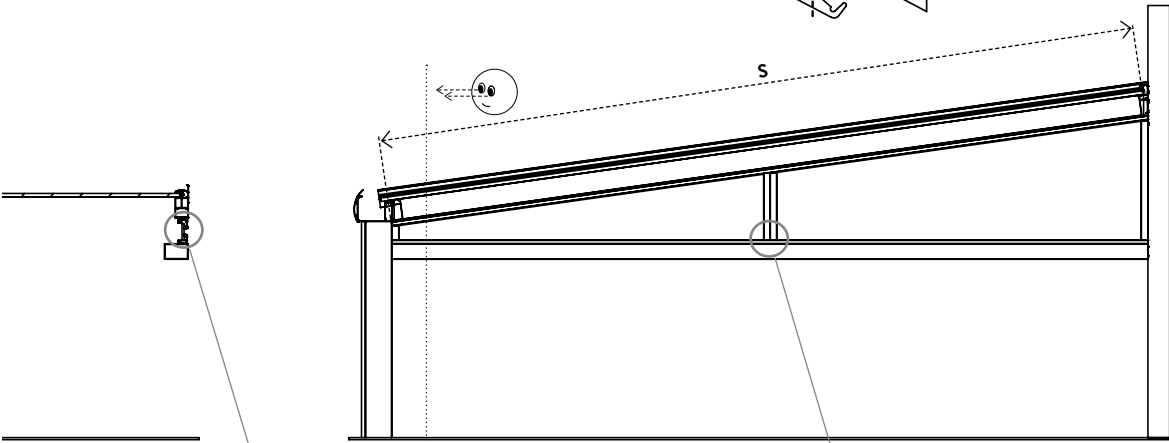
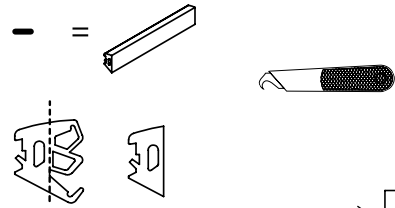
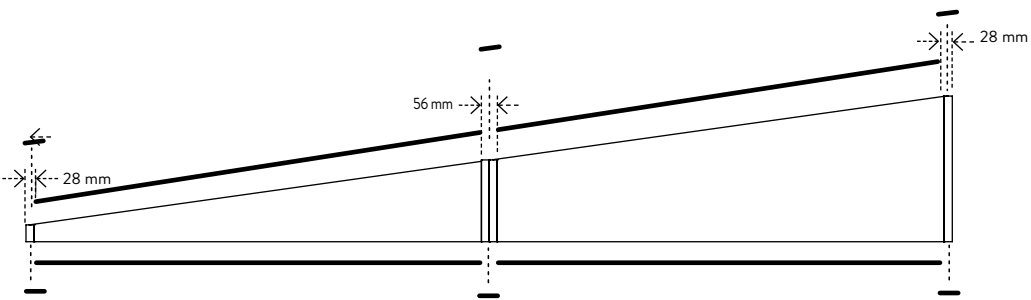
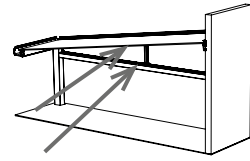
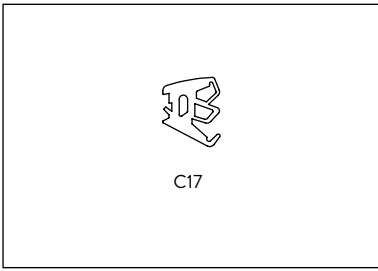

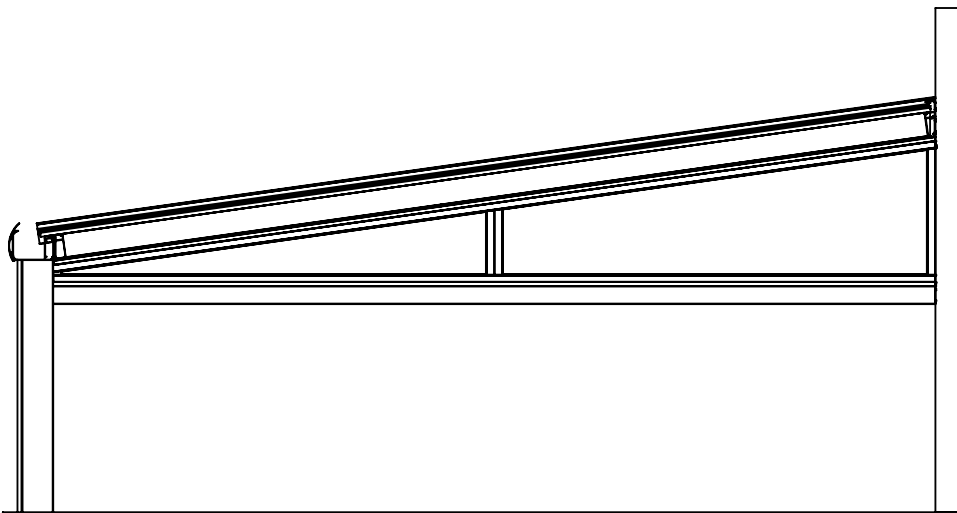
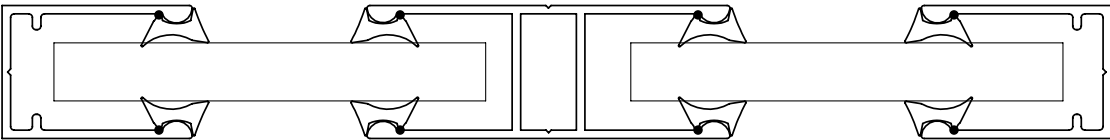
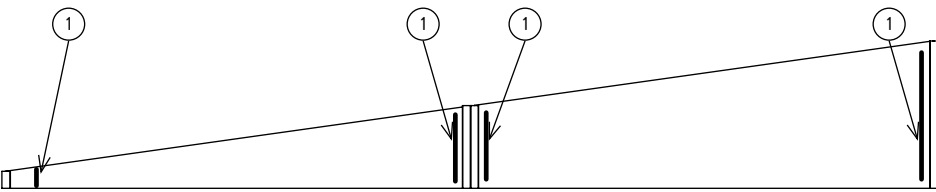
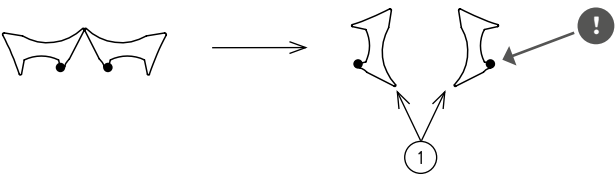
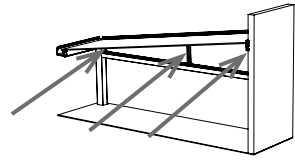
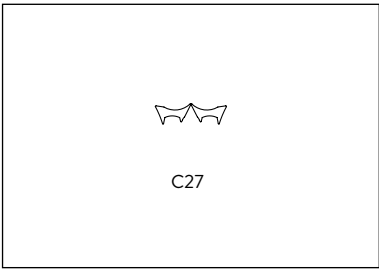

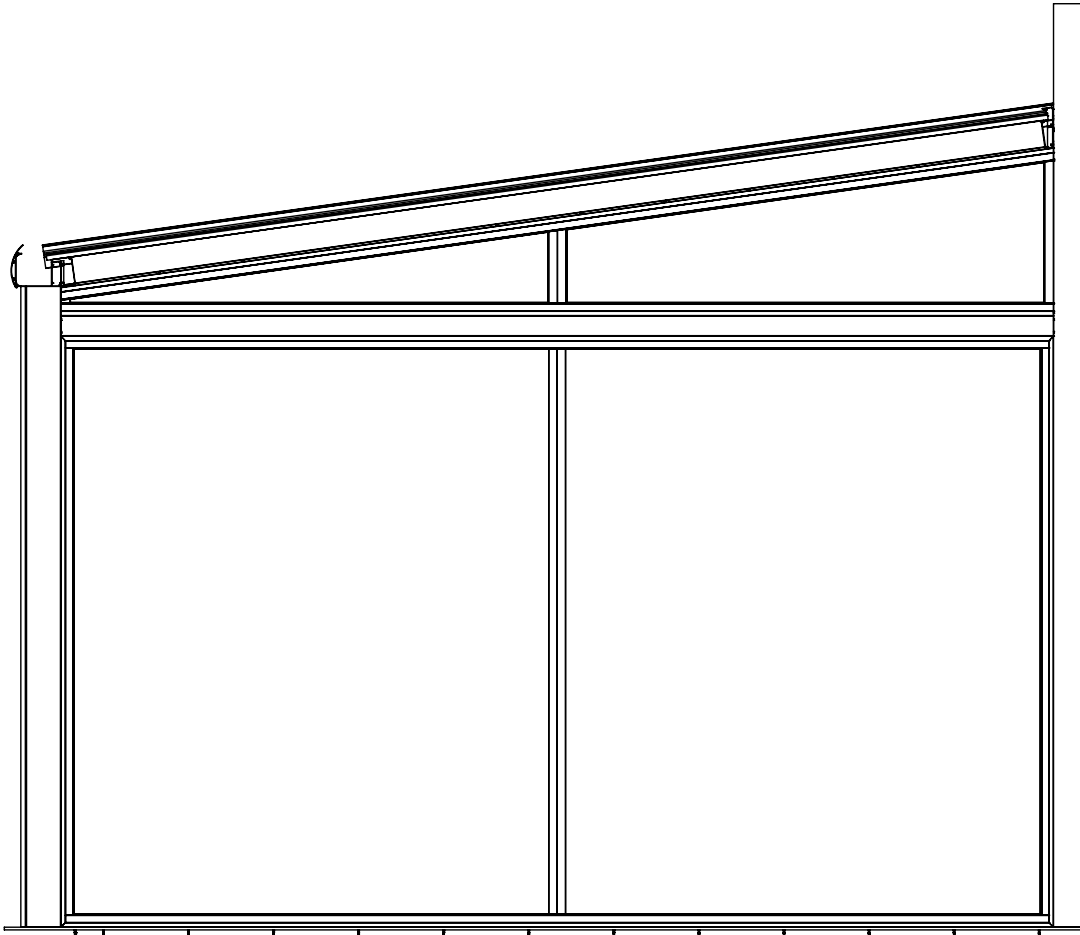

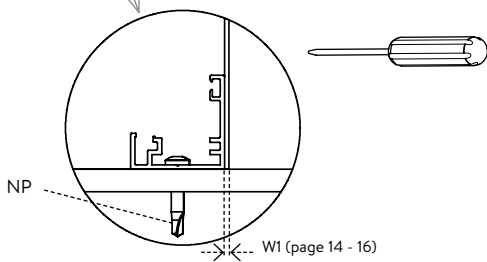
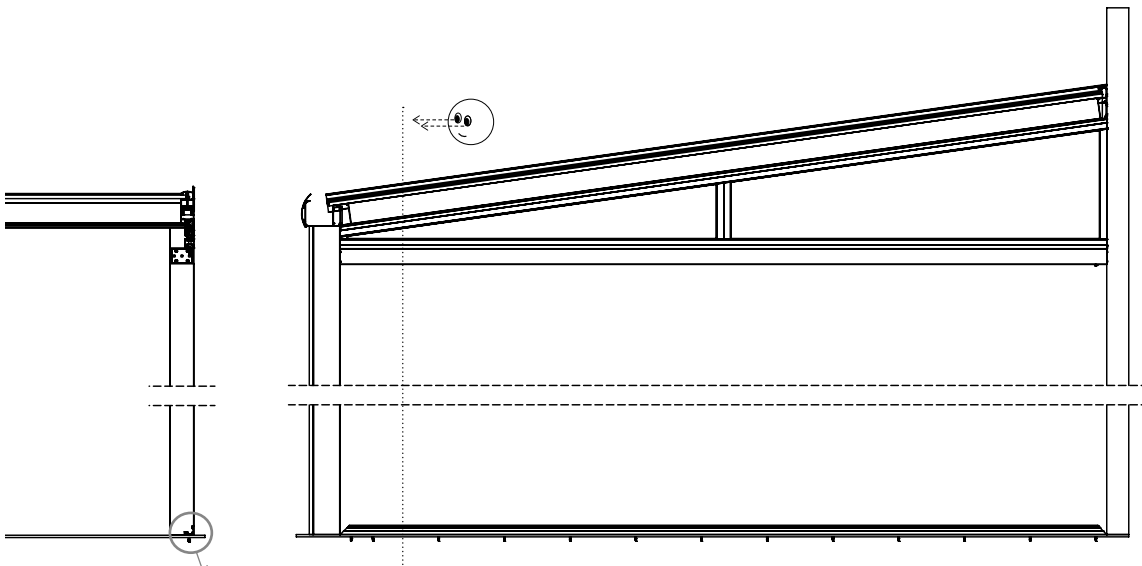
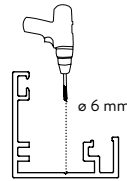
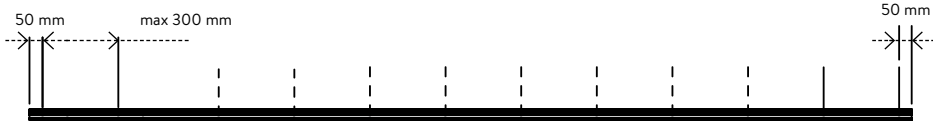
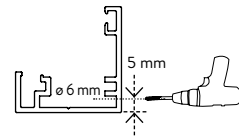
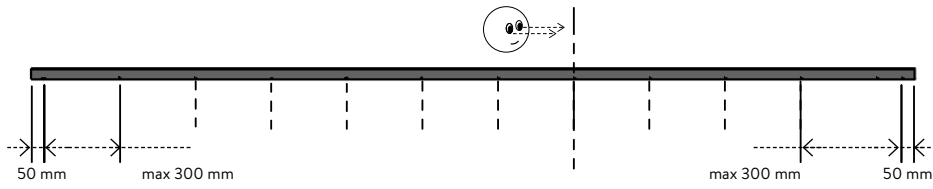
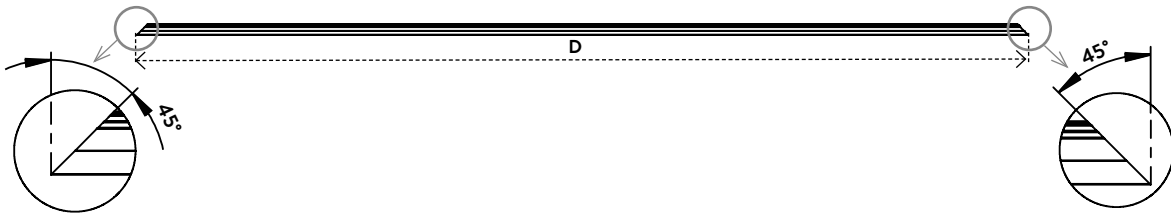
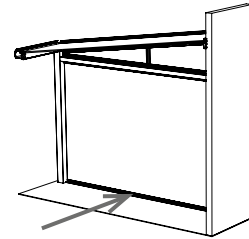
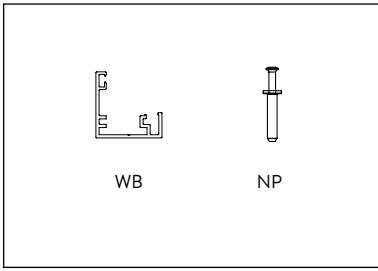

W1 (page 14 - 16)

