

Alva Self-closing patch fitting EN3 / ANSI 3

Montageanleitung · Instruction Manual · Instructions d'installation · Instrucciones de instalación · Istruzioni per l'installazione · Szerelési útmutató · Monteringsanvisning · Installatie-instructies · Инструкция по монтажу

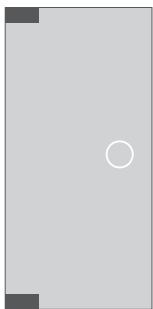

max 1.000 mm
(39-3/8")



8 - 12,7 mm
(5/16 - 1/2")



max 2.590 mm
(102")



max 100 kg
(220 lbs)



Nicht für VSG geeignet
(Do not use with laminated
safety glass)

Verwendung mit Verbundsicherheitsglas:
Nur in Verbindung mit strukturellem PVB
oder Ionome-Membran. Der Nachweis der
Eignung für den Anwendungsfall liegt in
der Verantwortung des Planers und / oder
Verarbeiters.

Use with laminated safety glass:
Only to be used with structural PVB or
ionomer interlayer. Proof of suitability for the
intended application is the responsibility of
the designer and / or fabricator.

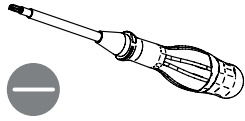
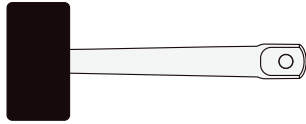

ø 10 mm
(3/8")



3



3

ø 6 mm
(1/4")

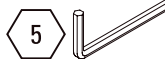

5

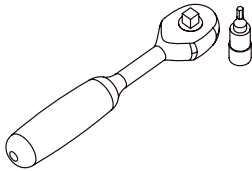

Mounting Kit



BO 5104734

Glass Cleaner



BO 5107911

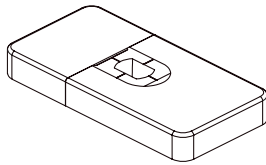
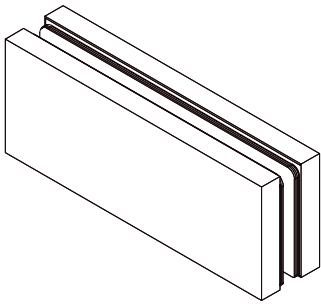

2x M8 x 30



2x Ø10 x 30

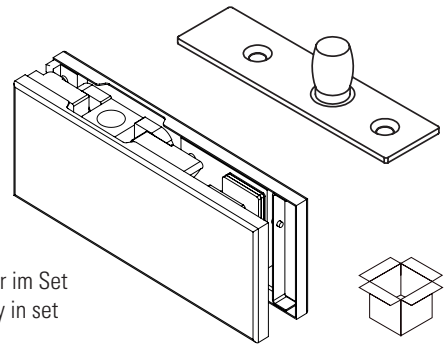

enthalten nur im Set
included only in set

Glasbearbeitung / Glass cutout | mm

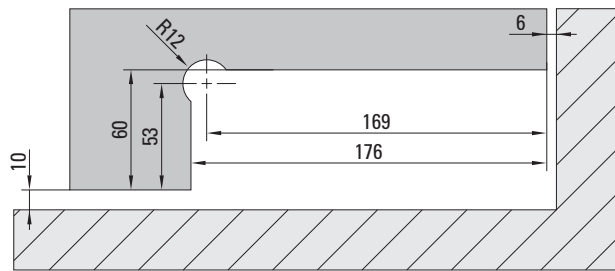
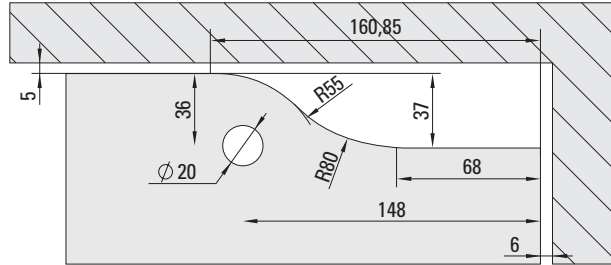
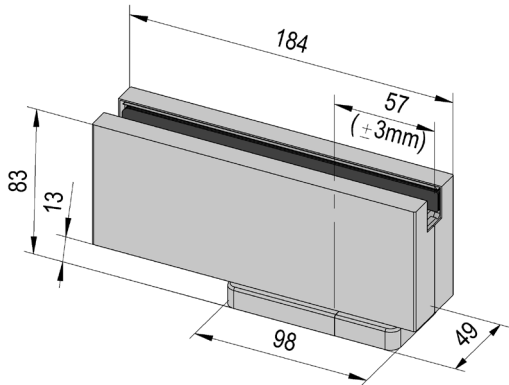
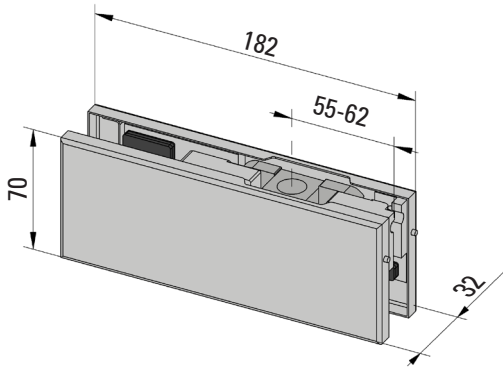

Glasbearbeitung / Glass cutout | inch

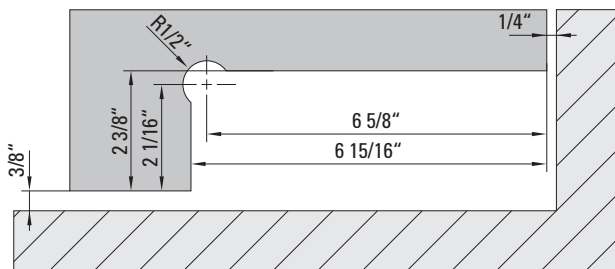
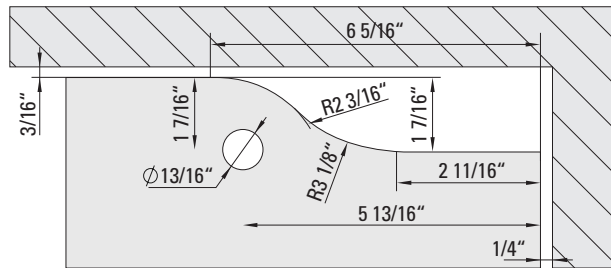
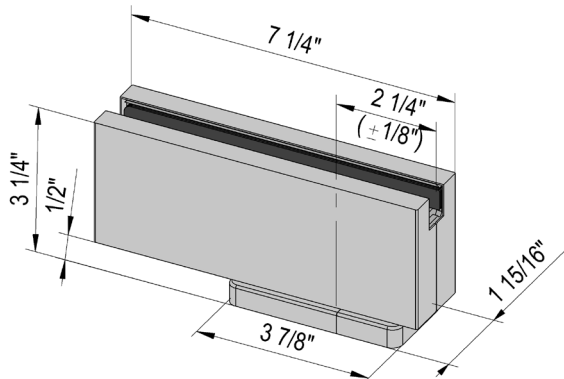
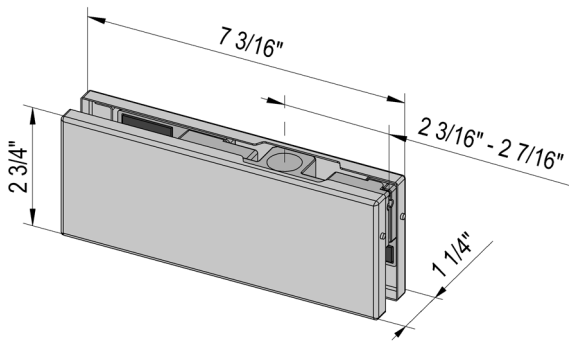

1

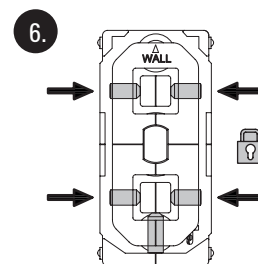
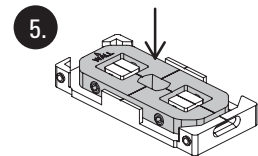
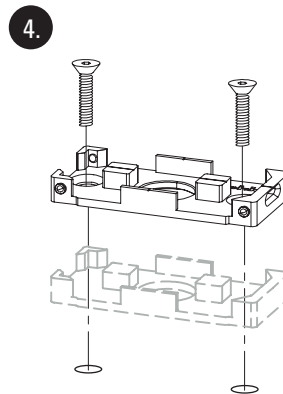
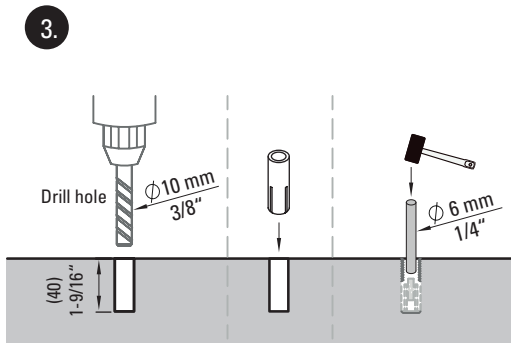
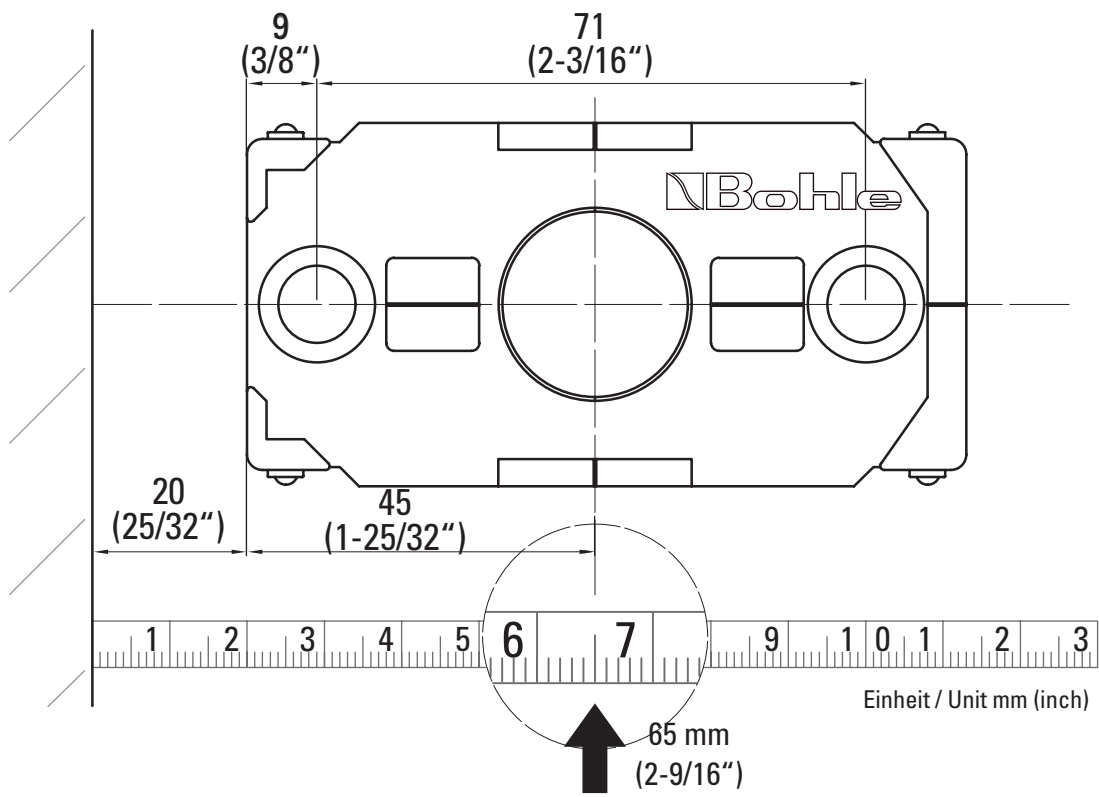
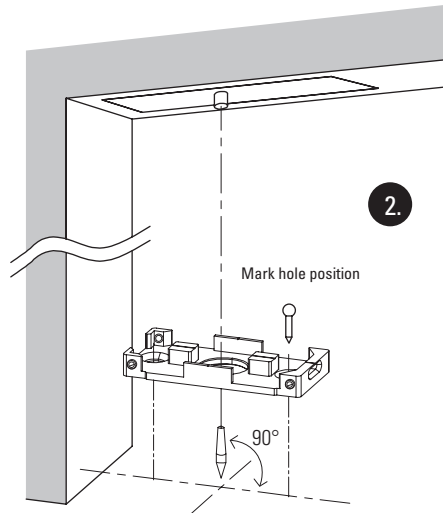
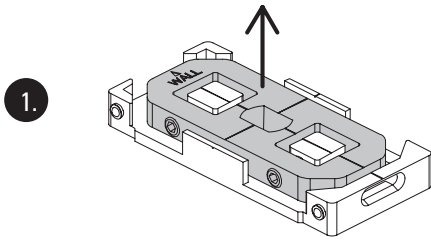

2

1.

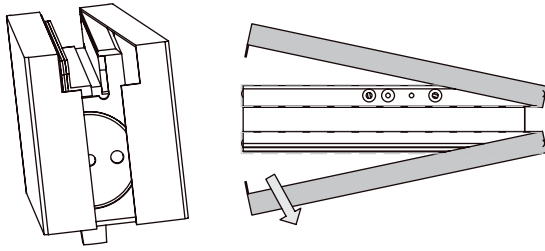

2.

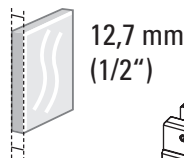
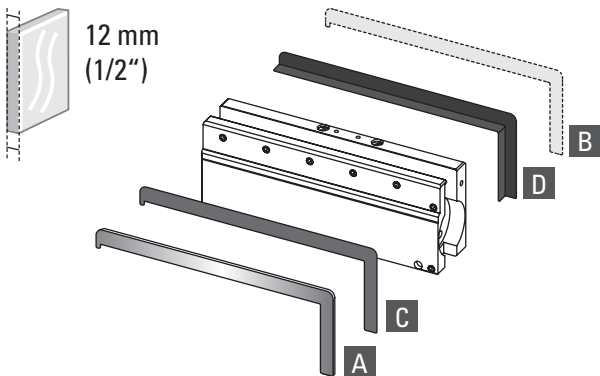
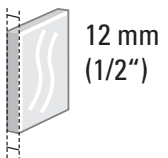
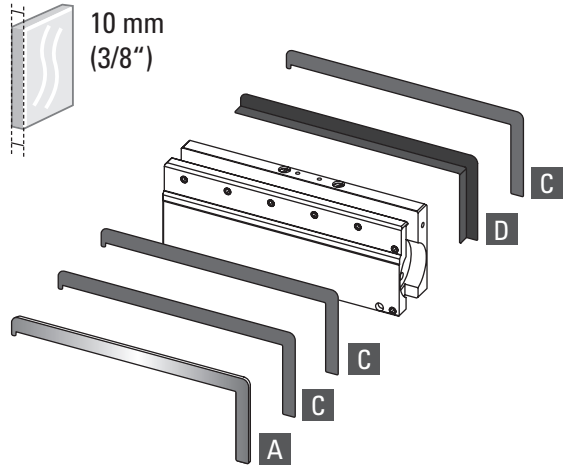
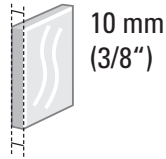
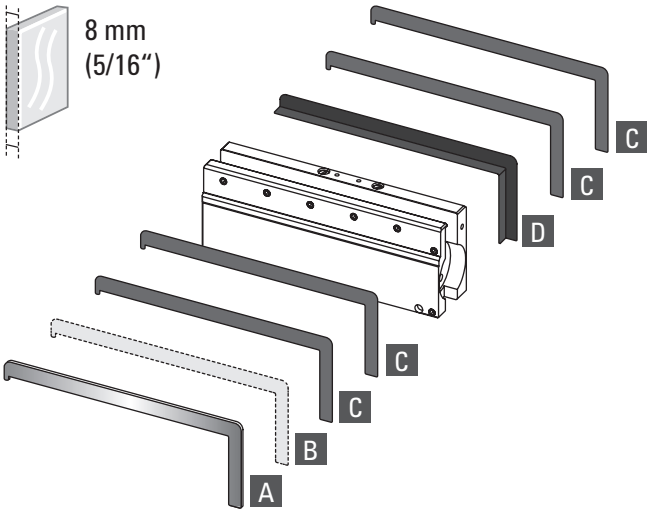
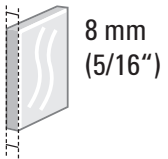
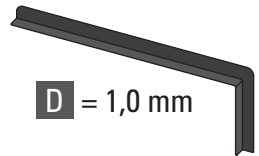
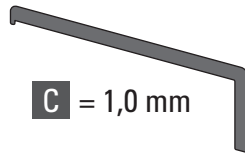
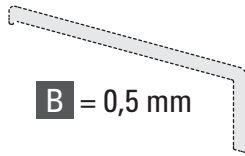
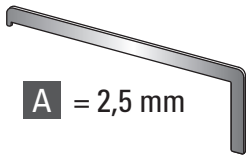
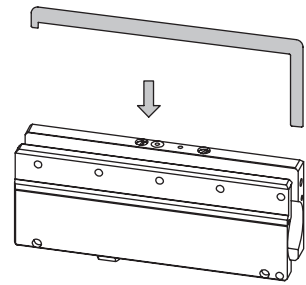

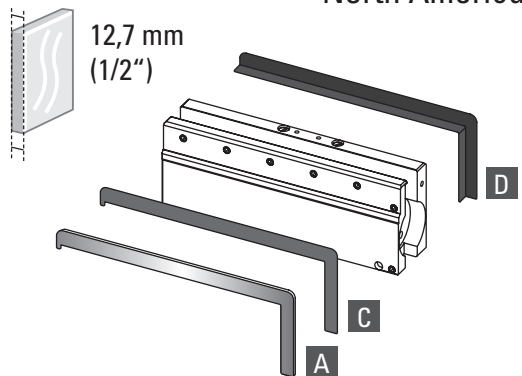

North America

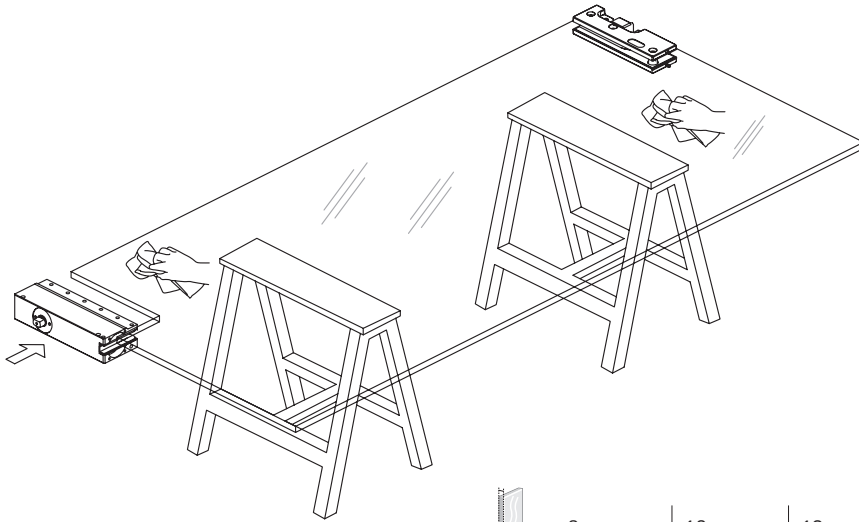

3



	8 mm	10 mm	12 mm	12,7 mm (1/2")
	2 x 2 mm*	2 x 2 mm*	2 x 2 mm*	2 x 2 mm*
	2 x 2 mm	2 x 1 mm	* pre-installed	

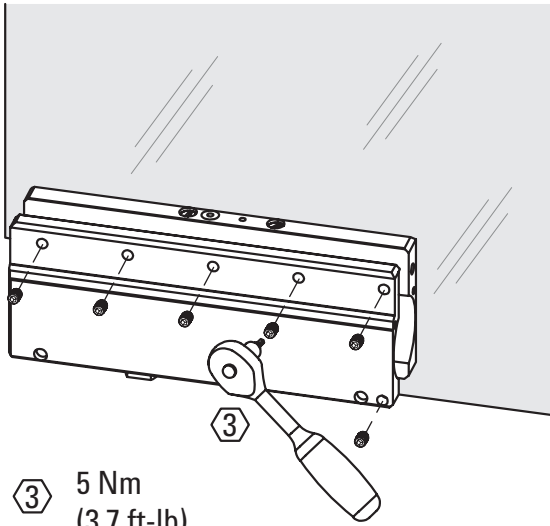

3 5 Nm
(3.7 ft-lb)

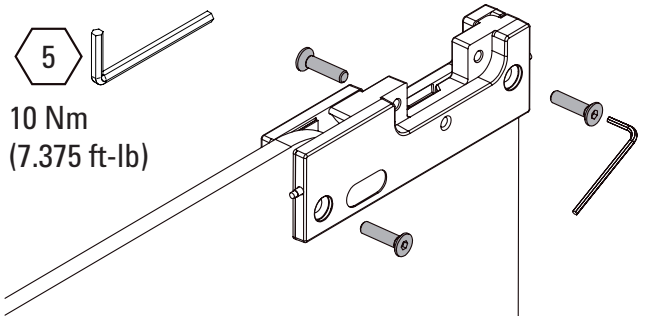
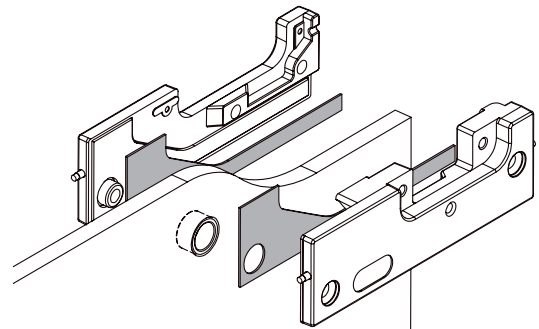

5 10 Nm
(7.375 ft-lb)

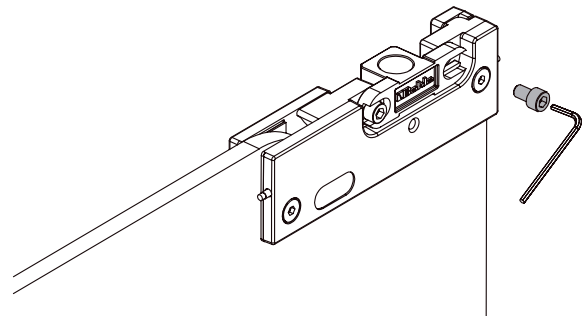
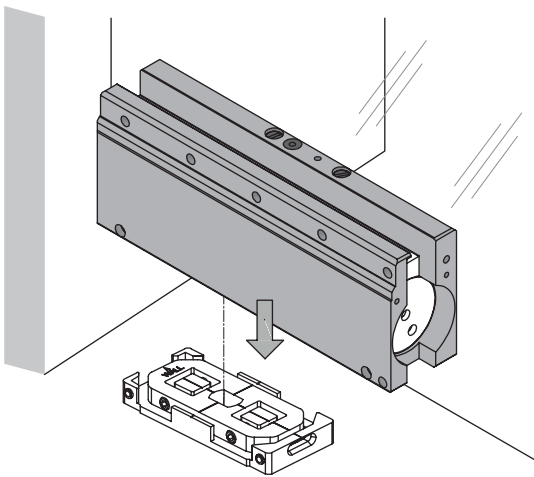

4

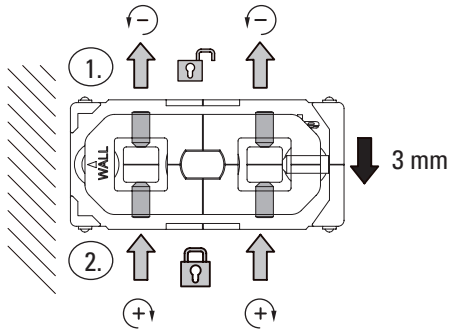
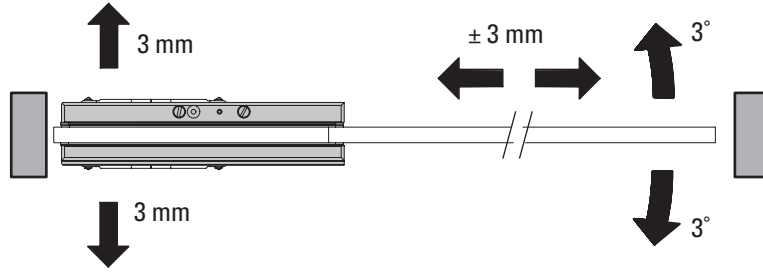
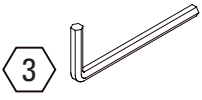

1x $\odot = 1 \text{ mm}$

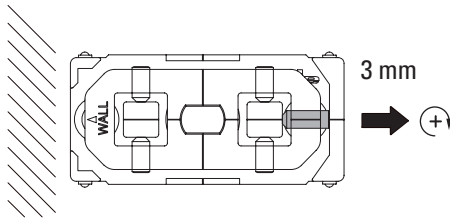
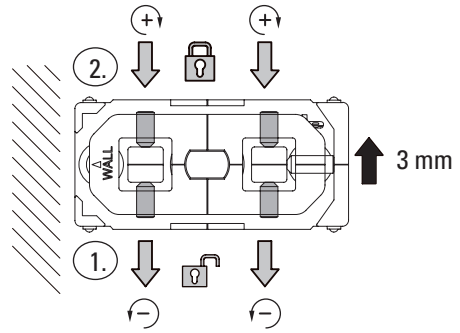

1x $\odot = 1 \text{ mm}$

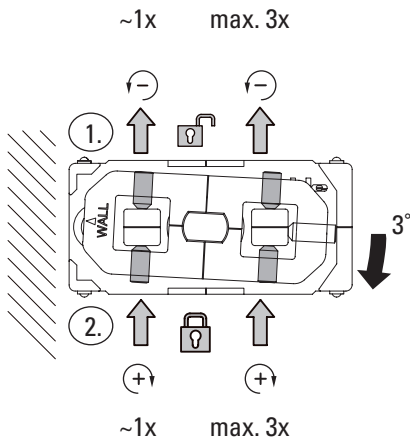
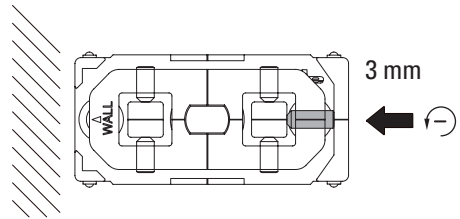

1x $\odot = 1 \text{ mm}$

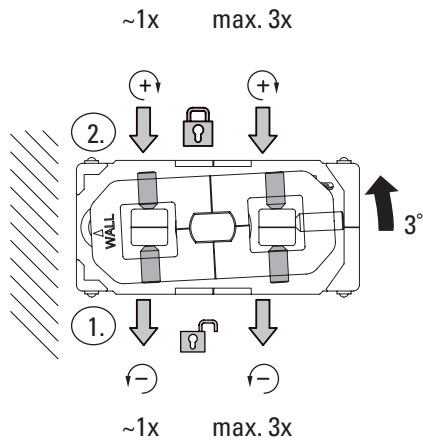

5

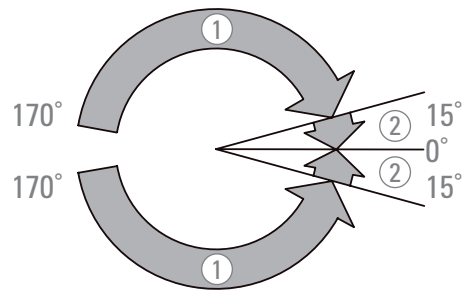
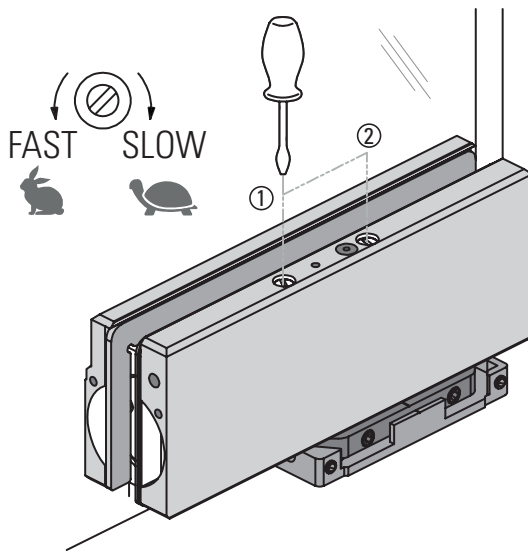

- ① Schließgeschwindigkeit / Closing Speed
- ② Endschlag / Latching Speed

6

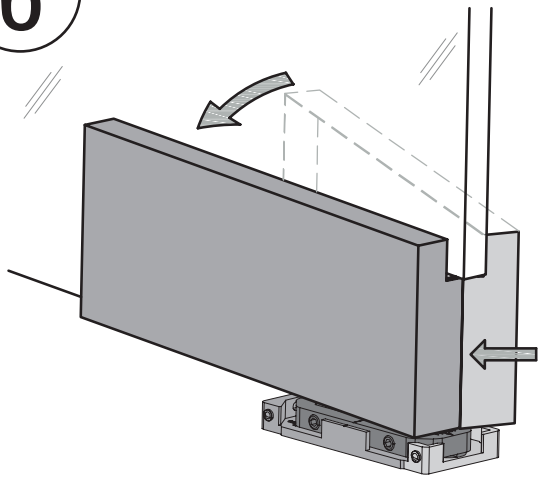

7

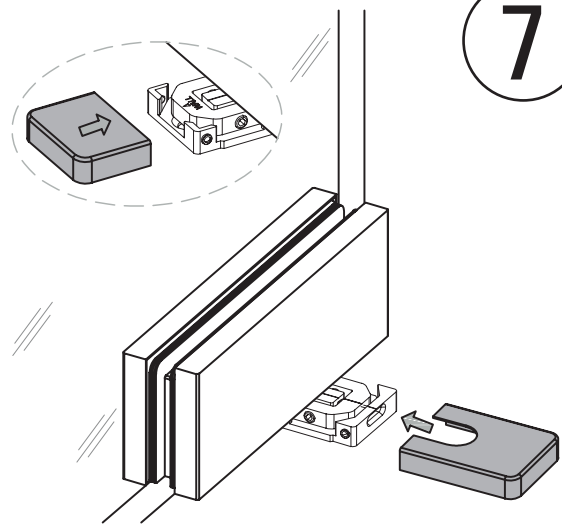

8

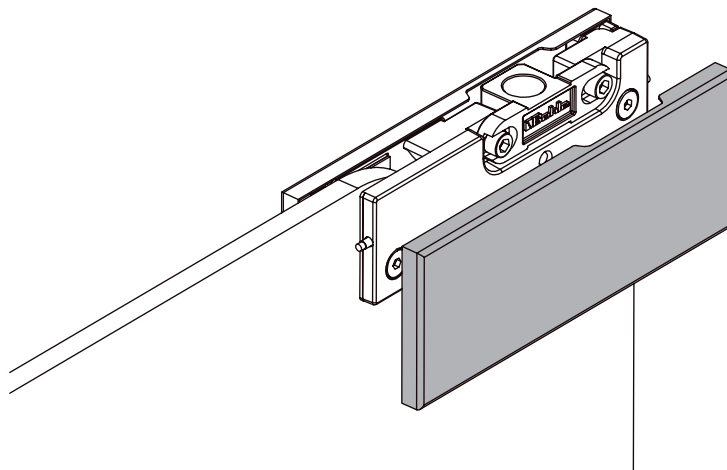

EN IMPORTANT INSTALLATION NOTES

After installation please check and test:

1. Open the door leaf to its maximum opening angle and release. The door leaf should close fully into the door frame and overcome the latch.
2. Open the door leaf and rest the latch bolt on the strike plate. Release the door leaf. The door closer should have sufficient power to close the door leaf.

Maintenance:

1. Check the door closer every three months to ensure all fixings are secure and adjusted. If necessary, adjust the closing and latching speed to ensure functional and smooth operation of the door in accordance with BS EN1154:1997.
2. Apply oil lightly to the arm knuckle joint and door hinges.

DE WICHTIGE INSTALLATIONSHINWEISE:

Nach der Installation bitte folgende Funktionen überprüfen und testen:

1. Öffnen Sie die Tür bis zum maximalen Öffnungswinkel und lassen Sie sie dann los. Damit die Falle vollkommen ins Schließblech fällt, muss der Widerstand überwunden werden.
2. Öffnen Sie die Tür und führen Sie die Falle an die Kante des Schließblechs. Lassen Sie die Tür dann los. Die Kraft des Türschließers sollte ausreichend sein, um die Tür zu schließen.

Wartung:

1. Den Türschließer alle drei Monate überprüfen und sicherstellen, dass die Beschläge sicher sind und richtig sitzen. Die Schließgeschwindigkeit und den Endanschlag bei Bedarf so einstellen, dass eine sachgemäße und reibungslose Verwendung der Tür nach Maßgabe von BS EN 1154:1997 möglich ist.
2. Die Scharniere und Türbeschläge leicht schmieren.

FR INFORMATIONS DE MONTAGE IMPORTANTES :

Après le montage, veuillez vérifier et tester les fonctions suivantes :

1. Ouvrez la porte jusqu'au maximum et lâchez-la ensuite. Afin que le pêne rentre complètement dans la gâche, il doit franchir le point de résistance.
2. Ouvrez la porte et amenez le pêne au bord de la gâche. Lâchez la porte. La force du ferme-porte devra être suffisante pour fermer celle-ci.

Entretien :

1. Tous les trois mois, contrôlez le ferme-porte et assurez-vous que les ferrures soient en bonne position. Au besoin, réglez la vitesse de fermeture et la butée de fin de course de manière à assurer une utilisation adéquate et sans difficulté de la porte selon les directives de BS EN 1154:1997.
2. Graissez légèrement les charnières et les ferrures.

ES NOTA IMPORTANTE DE INSTALACIÓN

Después de la instalación inspeccionar y comprobar las siguientes funciones:

1. Abra la puerta hasta alcanzar el máximo ángulo de apertura y suéltela a continuación. La puerta deberá cerrarse completamente en el marco de la puerta y superar el pestillo.
2. Abra la puerta y acerque el picaporte al canto del cerradero. Después suelte la puerta. La fuerza del sistema de cierre deberá ser suficiente para cerrar la puerta.

Mantenimiento:

1. Compruebe el sistema de cierre cada tres meses y asegúrese de que todas las bisagras se mantienen correctamente colocadas. Si fuere necesario, ajuste tanto la velocidad de cierre como los topes finales para que permitan el uso adecuado y sin problemas de la puerta acorde con BS EN 1154:1997.
2. Lubrique levemente el pivote y las bisagras de la puerta.

IT IMPORTANTI NOTE DI MONTAGGIO

Dopo il montaggio verificate e testate:

1. Aprire la porta al massimo angolo di apertura e rilasciarla. La porta dovrebbe chiudersi completamente nel telaio e superare il fermo
2. Aprire la porta e appoggiare il chiavistello sul piattello. Rilasciare la porta. Il chiudiporta deve avere forza sufficiente per chiudere la porta.

Manutenzione:

1. Controllate il chiudiporta ogni 3 mesi ed assicurarsi che le viti siano ben chiuse. Se necessario regolare la velocità di avvicinamento e chiusura per avere un funzionamento morbido e regolare della porta secondo BS EN1154:1997.
2. Oliare leggermente le cerniere

NL BELANGRIJKE INSTALLATIE AANWIJZINGEN:

Na de installatie s.v.p. controleren en testen:

1. Open de deur tot de maximale openingshoek en laat dan los. Om de klink volledig in de slotplaat te laten vallen, moet de weerstand overwonnen worden.
2. Open de deur en leid de grendel naar de rand van de sluitplaat. Laat vervolgens de deur los. De kracht van de deurdranger moet voldoende zijn om de deur te sluiten.

Onderhoud:

1. Controleer de deurdranger iedere drie maanden en zorg ervoor dat het beslag goed vastzit.
2. Stel zo nodig de sluitsnelheid en de aanslag zodanig in dat een goed en soepel gebruik van de deur mogelijk is volgens BS EN 1154: 1997.

HU FONTOS TELEPÍTÉS MEGJEGYZÉSEK:

Telepítés után ellenőrizze és tesztelje a következő funkciókat:

1. Nyissa ki az ajtót a maximális nyitási szögben, majd engedje el. Ahhoz, hogy a zárnyelv teljesen beakadjon a zárlemezbe, az ellenállást le kell küzdeni.
2. Nyissa ki az ajtót és vezesse a zárnyelvet a zárlemez széléhez. Ezután engedje el az ajtót. Az ajtócsukó erejének elegendőnek kell lennie az ajtó bezárásához.

Karbantartás:

1. Ellenőrizze az ajtócsukót háromhavonta, és győződjön meg róla, hogy a szerelvények megfelelően rögzítve vannak. Szükség esetén állítsa be a zárási sebességet és a határolót úgy, hogy az ajtó működése megfelelő és zökkenőmentes legyen a BS EN 1154:1997 szerint.
2. Finoman kenje meg a zsanérpántokat és az ajtószelvényeket.

RU ВАЖНЫЕ УКАЗАНИЯ ПО УСТАНОВКЕ:

После установки необходимо проверить следующие функции:

1. Откройте дверь до максимального угла открытия, а затем отпустите ее. Чтобы дверь ровно остановилась в дверном проеме, язычок должен зайти в ответную часть.
2. Откройте дверь и поставьте язычок на край проема. Затем отпустите дверь. Сила дверного доводчика должна быть достаточной, чтобы закрыть дверь.

Уход:

1. Дверь необходимо проверять каждые 3 месяца, чтобы удостовериться, что вся фурнитура надежно закреплена. При необходимости установите скорость закрытия и ограничитель, чтобы обеспечить правильное и плавное использование двери в соответствии с нормой BS EN 1154: 1997.
2. Слегка смажьте все шарниры и фурнитуру.